

Procedure for Calibrating Hot Filament Ionization Gauges Against a Reference Manometer in the Range 10^{-2} – 10^{-5} Torr

Foreword

This Foreword is not a part of AVS 6.4-1969. This publication specifies practices tentatively approved as standard by the American Vacuum Society for the calibration of hot filament ionization gauges against a reference manometer in the range 10^{-2} – 10^{-5} Torr and is one of a series published by the American Vacuum Society. It contains data secured from many sources and represents the best thinking of a number of experts in the field. After several years of use this standard will be forwarded to the USA Standards Institute with the request that it be used as a basis for a USA Standard. Suggestions for improvement gained in use of this standard will be welcome. They should be sent to the American Vacuum Society, 335 East 45 Street, New York, New York 10017. The AVS Committees which drafted and approved this standard had the following personnel at the time of approval.

AVS Subcommittee 6

Vacuum Gauges

- S. Ruthberg, Chairman, *National Bureau of Standards*
- J. M. Benson, *Hastings-Raydist, Inc.*
- K. C. Brandt, *McDonnell Douglas Co.*
- T. Connor, *Bendix Vacuum Division*
- H. J. Eppig, *General Electric Co.*
- A. Guthrie, *California State College, Hayward*
- D. Holkeboer, *Aerovac Corp.*
- W. S. Kreisman, *GCA Corp.*
- J. R. Miller, *AMSC Redstone Arsenal*
- A. Nerken, *Veeco Instruments, Inc.*
- D. W. Patterson, *The Boeing Co.*
- F. S. Reinath, *Univ. of California*
- J. R. Roehrig, *Norton Research Corp.*
- A. M. Thomas, *National Bureau of Standards*
- J. L. Vincent, *General Electric Co.*
- N. G. Wilson, *Univ. of New Mexico*
- A. M. Wittenberg, *Bell Telephone Co.*
- R. Wolfe, *MKS Instruments, Inc.*
- R. H. Work, *Hastings-Raydist, Inc.*
- P. Yeager, *NASA Langley*

AVS Standards Committee

- A. Nerken, Chairman, *Veeco Instruments, Inc.*
- B. B. Dayton, *Bendix Vacuum Division*

- A. Guthrie, *California State College, Hayward*
- D. P. Johnson, *National Bureau of Standards*
- C. F. Morrison, *Granville-Phillips Co.*
- G. E. Osterstrom, *The Welch Scientific Co.*
- F. S. Reinath, *University of California*
- S. Ruthberg, *National Bureau of Standards*
- H. Schwarz, *Rensselaer Polytechnic Inst. of Conn.*
- D. L. Stevenson, *Bendix Vacuum Division*
- P. F. Varadi, *Comsat Laboratories*
- W. R. Wheeler, *Varian Associates*
- P. R. Yeager, *National Aeronautics & Space Administration*

1. Scope

1.1. Procedures are given for the calibration of hot cathode ionization gauges and gauge tubes by direct comparison against a McLeod gauge or other absolute manometer in the pressure range of 10^{-2} – 10^{-5} Torr.

1.2. Since an ionization gauge comprises an independent sensor (the ionization gauge tube), electrical controls, and an ion current ammeter, calibration may be applied to the gauge as a complete system or to the tube itself as an independent sensor, provided a properly calibrated control circuit is used. A gauge tube so calibrated may then be used with any other electrically calibrated, compatible, control circuit to provide a calibrated gauge. See Appendix B5.

2. Definitions and Referenced Documents

2.1. Definitions

2.1.1. *Ionization Gauge.* A vacuum gauge comprising a means of ionizing the gas molecules and a means of correlating the number of ions produced with the pressure of the gas.

2.1.2. *Ionization Gauge Tube.* The part of the ionization gauge which contains the elements exposed directly to the vacuum system including the pressure sensing means, the envelope or means of supporting the operating elements, and any connecting tube attached permanently to the envelope.

2.1.3. *Ionization Gauge Control Circuit.* That part of the ionization gauge which comprises the electrical circuits necessary to energize the tube, to control and

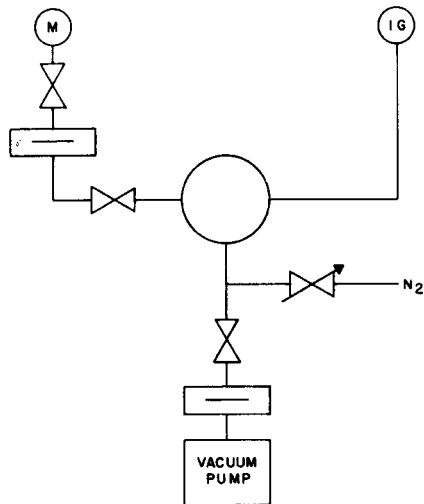

FIGURE 1. Vacuum system for calibration of ionization gauges.

measure currents or voltages, and in some cases to supply power for degassing of tube elements.

2.1.4. Gauge Calibration Factor. The ratio of the gauge indication to the true pressure (P). The gauge indication may be either a pressure indication ($P_{\text{indicated}}$) or a current indication (i_c). In these terms, gauge calibration factor is equal to either $P_{\text{indicated}}$ divided by P or i_c divided by P .

2.1.5. Tube Calibration Factor. The ratio of the actual collector (ion) current to the product of the true pressure and the electron emission current: $i_+/(i_-P)$ at stated electrode potentials.

2.2. General Terms. "Glossary of Terms Used in Vacuum Technology," issued by the American Vacuum Society (Pergamon Press Inc., New York, 1958).

2.3. Symbols. AVS Standard (Tentative) 7.1-1966 "Graphic Symbols."

2.4. Instrument References.

2.4.1. Manometer. AVS Standards pertaining to the McLeod gauge or other reference manometer that may be used as a standard in calibrating the ionization gauge.

2.4.2. Control Circuit. AVS procedures pertaining to the calibration of the control circuit.

3. Outline of Procedures

3.1. Calibration is obtained by the comparison of ionization gauge readings to those derived with the reference instrument. Suitable pressure points may be generated by balancing the gas flow in and out of the

test chamber of a vacuum system, as represented in the diagram of Fig. 1. Gas influx may be regulated by a leak valve on the input line, while pumping speed at the chamber may be controlled by a valve above the vacuum pump.

3.2. Calibration of the ionization gauge tube, as distinguished from the ionization gauge, requires the additional measurements with calibrated meters of the electrode potentials applied to the tube, operating emission current, and the consequent collector (ion) current.

4. Test Conditions

4.1. Gas. The test gas is to be nitrogen of not more than 0.01% impurity. Note: Such gas is readily available as prepurified grade.

4.2. Temperature. Ambient temperature is to be $23^\circ\text{C} \pm 3^\circ$.

5. Apparatus

5.1. Reference Instrument. McLeod gauge or other absolute manometer.

5.2. Vacuum System. Assembled as shown in Fig. 1 and to meet the following requirements:

5.2.1. Ultimate Pressure. The system must produce a vacuum of 1×10^{-7} Torr or less before admission of N_2 .

5.2.2. Test Chamber. The test chamber volume is to be at least ten times the ionization gauge tube volume or at least 1 liter in the case of a nude tube.

5.2.3. Tube Connection. The gauge tube may be sealed to the test chamber by any suitable means which will not permit vapor to stream from the seal directly into the gauge tubulation. Since all ionization gauges have some pumping action, the conductance of the tubulation between the major tube volume and the test chamber is a critical factor. This value of conductance should be maintained whenever the gauge tube is used. The effect of this factor can be diminished by use of a conductance large compared to gauge pumping speeds.

5.2.4. Tube Location

5.2.4.1. Test gauges and reference manometers are to be placed symmetrically about the chamber to minimize pressure differentials.

Note: The position of the tube relative to the chamber wall and the temperature of the portion of the chamber wall exposed to the tube are factors in the gauge calibration and, hence, should duplicate actual usage as nearly as possible.

5.2.4.2. Placement must be such that no detectable electronic, ionic, or magnetic interferences occur.

5.2.5. *Gas Leak.* The gas leak must be below the calibration chamber and pointed toward the pump or so baffled as to prevent gas from streaming directly toward the gauges.

5.3. Control Circuit

5.3.1. *Gauge Calibration.* Calibration of the gauge as a complete unit, i.e., tube and control circuit together, requires that the tube and control circuit be compatible according to manufacturer's recommendations on values and operation. After calibration, operation of either part with another gauge tube or control circuit will not necessarily provide a calibrated system.

5.3.2. *Tube Calibration.* Calibration of the ionization gauge tube itself requires calibrated facilities for the measurement of the currents and applied potentials. A commercially available control circuit may be used if electrically calibrated, or potentials can be derived from individual regulated power supplies adjusted to the desired values. Emission and collector (ion) currents are then measured with suitable ammeters.

5.4. Thermometers

5.4.1. A thermometer accurate to $\pm 1^\circ\text{C}$ shall be placed near the test chamber and shielded from heat radiation so as to indicate true ambient temperature.

5.4.2. A second thermometer accurate to $\pm 1^\circ\text{C}$, or equivalent device, shall be placed in thermal contact with the test chamber.

6. Procedure

6.1. Assemble the system and reference manometer as shown in Fig. 1, connect the test gauge, and pump the system down.

6.2. Fill all cold traps.

6.3. Bake out the manometer if necessary.

6.4. Degas the test gauge according to the manufacturer's recommended procedure.

6.5. Ultimate pressure as indicated on the test gauge must be 1×10^{-7} Torr or less before proceeding.

6.6. With the ionization gauge operating, allow the test chamber temperature to come to a steady value relative to the ambient temperature for at least 1 h. Record the test chamber temperature.

6.7. Open leak valve and adjust pressure to the 10^{-5} Torr range.

6.8. Let the pressure stabilize until any change or fluctuation in indicated pressure within a 5-min period is less than the measurement precision. See Appendix B.

6.9. Adjust the emission current, and zero check the ion current ammeter. Record the test gauge collector ion current or indicated pressure and the emission current at the time the measurement is made with the absolute manometer or at the time the mercury closes the mercury cutoff in the McLeod gauge. Record the manometer readings and the ambient temperature.

6.10. Repeat 6.9 twice.

6.11. Increase the pressure in the system to successively higher pressures and repeat as in operations 6.8-6.10 at each step. At least three approximately equal steps per decade should be taken over the calibrating range at the same emission current.

6.12. If the test gauge tube has more than one filament, identify filaments, and repeat 6.4-6.11 for each additional filament. If more than one filament is used simultaneously, specify.

7. Presentation of Results

7.1. Derive the values of true pressure as measured with the manometer.

7.2. Report the following items.

7.2.1. *Ionization gauge tube and control circuit identification* by manufacturer, model number, and serial number.

7.2.2. *Date of Calibration.*

7.2.3. *Description of Any Irregularities.*

7.2.4. *Chamber Temperature.*

7.2.5. *Gauge Characteristic.* Tabulated values for each filament of indicated ion current (i_c) or indicated pressure, pressure as measured with the absolute manometer, emission current and line voltage. Report all test data. See Appendix B for calibration uncertainty, or

7.2.6. *Tube Characteristic.* Tabulated values for each filament of ion current (i_+), true pressure, emission current (i_-), grid-to-ground potential, filament-to-ground potential, and collector-to-ground potential. Report all test data. See Appendix B.

7.2.7. *Calibration Curve.* Graph gauge or tube calibration factor vs true pressure for each filament. Indicate all test data.

Appendices

Appendix A. Multiple Gauge Calibration.

A1. If gauges are operated one at a time with all other filaments and potentials off, procedures are as in the main text. If gauges are operated simultaneously, further precautions are necessary.

A2. Apparatus

A2.1. Test Chamber. Volume is to be at least ten times the total volume of the ionization gauge tubes operating simultaneously or at least 1 liter per tube.

A2.2. Tube Location

A2.2.1. Gauges should be arranged symmetrically on the test chamber to minimize pressure differentials.

A2.2.2. Tube placement must be such that no detectable electronic, ionic, or magnetic interference occurs.

A2.3. Control Circuit. The control circuits must be so electrically isolated that no detectable interference is observed between gauges when the control circuits are switched on and off and ionization gauge filaments are off.

Appendix B. Gauge Calibration Uncertainty.

B1. Concept. The foregoing procedure does not place limits on or specify stability, regulation, and accuracy but relies on error analysis for guidelines. The procedure may be applied to whatever final accuracy is desired or which is dictated by the apparatus at hand. Resultant dispersion will be apparent in the tabulated values and graph of 7.2.5-7.2.7.

B2. Factors

B2.1. The calibration process is actually the comparison of the ionization gauge response to the true pressure, with the ratio being the gauge calibration factor. The uncertainty of calibration is thus equivalent to the uncertainty in the calibration factor, with contributions from both terms of the ratio, i.e., the imprecision in the ionization gauge output reading, the drift and regulation in the gauge, the stability of the environment being measured, and the uncertainty in the measurement with the reference manometer.

B2.2. An evaluation of the calibration uncertainty can be derived in a number of ways. Repetitive measurement of a reasonable stable pressure point can give the dispersion. Or, dispersion can be derived from the calibration procedure given in the text, i.e., measurement at a number of different pressure points with analysis of the resultant data. A greater confidence along with insight into systematic errors follows detailed examination of the individual factors. An example of such a process follows.

B3. Ionization Gauge

B3.1. Gauge Calibration Factor. The calibration uncertainty is given as the relative error in R_g for

$$R_g = i_c/P,$$

or

$$R_g = P_{\text{ind.}}/P.$$

B3.2. Relative Error. If i_c and P can be treated as independent factors (e.g., any fluctuation or drift in P can be ascribed to uncertainty in P and where i_c is only an instrumental problem), the relative error in R_g is then the root-mean-square of those in i_c and P , or

$$E_{R_g}^2 = E_{i_c}^2 + E_P^2,$$

provided E_{i_c} and E_P are not vastly different. If i_c and P cannot be considered as independent factors, further relationship must be considered, or a maximum uncertainty may be used as equal to the sum of uncertainties.

B3.3. Error in P . The relative error in P is derived from the operational equations for the reference manometer. See pertinent AVS standard.

B3.4. Error in i_c . Since the ionization gauge is considered here to be a complete system for which no internal calibration has been applied to the control circuit, the relative error in i_c must be determined by experimental procedures, by observation of drift, noise, regulation, and of repeatability. This last factor requires repetitive measurements of a stable pressure. Standard deviations can then be deduced. Such experimentally determined uncertainty would include the effects due to vacuum system instability and power line fluctuation.

B4. Ionization Gauge Tube

B4.1. Tube Calibration Factor. The calibration uncertainty is given as the relative error in R_t for

$$R_t = i_+/(i_-P).$$

B4.2. Relative Error. The relative error in R_t is thence

$$E_{R_t}^2 = E_{i_+}^2 + E_{i_-}^2 + E_P^2.$$

B4.3. Error in i_+ . The uncertainty in the value of i_+ is due to the imprecision in the measurement of i_+ with the ion current ammeter and to the systematic variations of i_+ due to the applied potentials. That is, i_+ at constant i_- is a function of the filament-to-grid accelerating potential and the (ion) collector bias. If these potentials are not physically independent in behavior, the resultant uncertainty is

$$di_+ = (\partial i_+/\partial e_{fg}) de_{fg} + (\partial i_+/\partial e_c) de_c,$$

where e_{cf} is the collector bias and e_{fg} the filament-to-grid potential. This filament-to-grid potential is usually obtained as the difference between the filament bias and grid bias; whence,

$$de_{fg} = de_g - de_f.$$

Each differential is the *rms* value of the imprecision in the measurement of that potential and the expected drift or fluctuation. If the potentials are not coupled and respond randomly to line drift, etc., then di_+ is the *rms* value of the two terms. Then,

$$E_{i_+}^2 = (\Delta i_+/i_+)^2 + (di_+/i_+)^2,$$

where Δi_+ represents the imprecision in the measured value of i_+ . The dependence of i_+ on e_{fg} is generally obtained experimentally. Normally the accelerating potential is so chosen as to minimize the value of $\partial i_+/\partial e_{fg}$. The relationship of i_+ to e_{cf} at constant e_{fg} is also a relatively slowly changing function. The evaluation of these partial derivatives must be done experimentally for good accuracy; however, approximation of these values from characteristic curves of the tube type may be sufficient for many cases. The uncertainty

in the potentials due to drift and instability is derived from the measured drift rates and regulation of the power supplies. These can be minimized by the use of well-regulated supplies or by adjustment of values at the time each calibration point is obtained.

B4.4. Error in i_- . The relative error in the emission current is equal to the relative uncertainty in the measurement at the time i_+ is determined.

B4.5. Error in P . The relative error in P is again derived from the operational equations for the reference manometer.

B5. Ionization Gauge Tube with a Calibrated Control Circuit. The measurement uncertainty will then include those applicable to both components. An additional systematic error will arise and must be included if the calibrated control circuit does not apply those potentials to the tube for which the tube was originally calibrated. The effect of small differences from the tube calibration potentials might be corrected by reference to the characteristic curves of the tube type. See *B4.3*.